

BIO-CEL® 104

Submerged MBR Module for Wastewater Treatment

The BIO-CEL® MBR series is ideal for biological wastewater treatment in industrial and municipal applications. BIO-CEL MBR combines the benefits of traditional hollow fiber and plate and frame configurations without any of their inherent disadvantages. The module has an extremely high packing density due to the thin and self-supporting membrane sheets, and the laminate offers a self-healing mechanism.

MEMBRANE CHARACTERISTICS

Membrane	NADIR® UPI50
Membrane Polymer	Polyethersulfone (PES)
Nominal Pore Size	0.04 µm
Preservative	Glycerine 20 % / Sodium benzoate 3 %

MODULE SPECIFICATIONS

Housing Material Options	Polyvinyl chloride (PVC) Polyethylene (PE)
Drainage Layer	Polyester (PET)
Diffusors Material Options	Membrane hose: Polyurethane (PUR) / Silicone (SI) Support tube: Polypropylene (PP)
Nominal Membrane Area	104 m ² (1120 ft ²)

OPERATING PARAMETERS

pH Range	2.0 - 11.0
Temperature Range	5 - 40°C (41 - 104°F)
Maximum TMP during Filtration	- 400 mbar (-5.8 psi)
Maximum TMP during Regular Backwash	+150 mbar (+2.2 psi)
Recommended Air Scour Rate ^a	60 Nm ³ /h (37 SCFM)
Recommended MLSS in MBR Tank	8 - 12 g/L
Maximum MLSS in MBR Tank	15 g/l
Maximum Particle Size in MBR Tank	2 mm
Total Chlorine Resistance	1,000,000 ppm•hr

a volumetric flow rate at standard conditions according to DIN ISO 2533:1979-12.

PHYSICAL DIMENSIONS

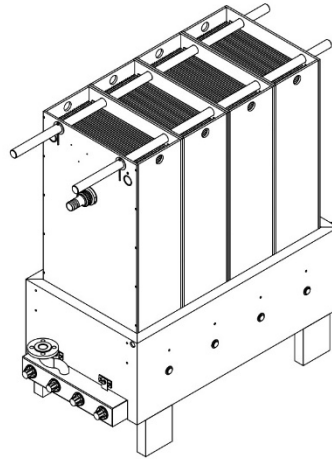

Dry Weight	260 kg (574 lb)
Wet Weight without Solids	330 kg (728 lb)
Maximum Load for Lifting^b	850 kg (1874 lb)
Length	1600 mm (5.3 ft)
Width	702 mm (2.3 ft)
Height	1563 mm (5.1 ft)
Filtration Tank Minimal Water Level	1750 mm (5.8 ft)
Connection for Permeate	2" Hose Nozzle PVC, for hose inner diameter 40 mm
Connection for Aeration	Flange DIN 2633 - Type C Series1 (ISO), PN16, DN32 x 42.2

^b Sludge deposit must be removed before lifting unit

IMPORTANT INFORMATION

Scope of Supply, Accessories & Spare Parts:

Please see BIO-CEL® 104 – Scope of Supply, Accessories and Spare Parts (TDS-WW003).

Storage & Handling:

BIO-CEL MBR modules must be handled and stored appropriately to ensure proper operation and to prevent membrane damage. Please see BIO-CEL® MBR – Storage Conditions (TB-WW002).

MANN+HUMMEL Water & Fluid Solutions reserves the right to change specifications without prior notification.

Contact

Europe

Germany: +49 611 962 6001
Italy: +39 0721 1796201
info@microdyn-nadir.com

Americas

USA: +1 805 964 8003
sales.mnus@microdyn-nadir.com

Asia

Singapore: +65 6457 7533
China: +86 10 8413 9860
waterchina@mann-hummel.com